

PARÇA KODU PART CODE	PARÇA ADI PART NAME	s ÖLÇÜSÜ (KALINLIK) s MEASURE (THICKNESS)	Malzeme Material	Kaplama / Coating		
				SN	AG	Nİ
TŞ 2466 DP	1 NO 2.TERMİNAL Ø2.7 K.A. =DP=	0.45±0.05	(CuZn30) Pirinç / Brass	-	-	-
TŞ 2466 RP	1 NO 2.TERMİNAL Ø2.7 K.A. =RP=	0.45±0.05	(CuZn30) Pirinç / Brass	-	-	-
TŞ 2466 RPK	1 NO 2.TERMİNAL Ø2.7 K.A. =RPK=	0.45±0.05	(CuZn30) Pirinç / Brass	+	-	-
TŞ 2466 RÇN	1 NO 2.TERMİNAL Ø2.7 K.A. =RÇN=	0.50±0.05	Paslanmaz Sac(430)	-	-	-

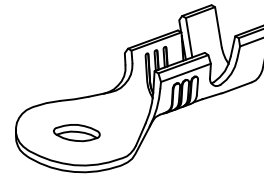

Perspektif
Perspective

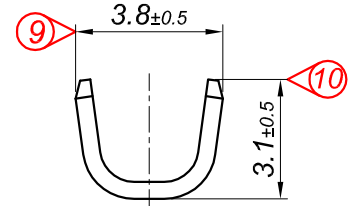
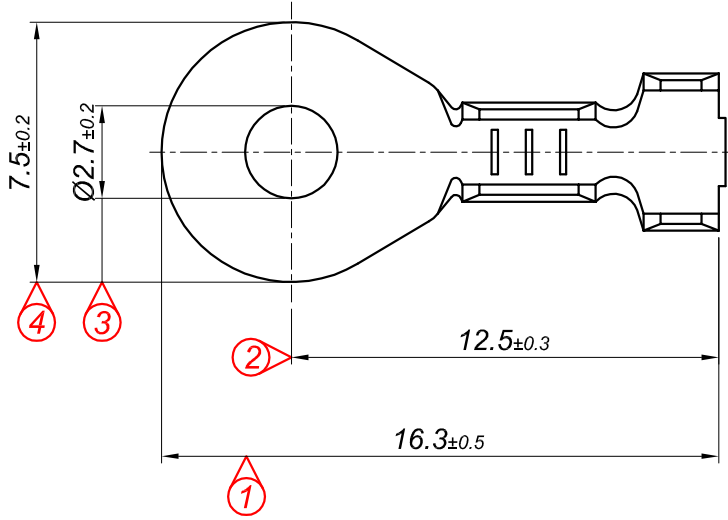
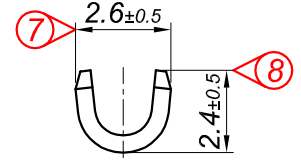
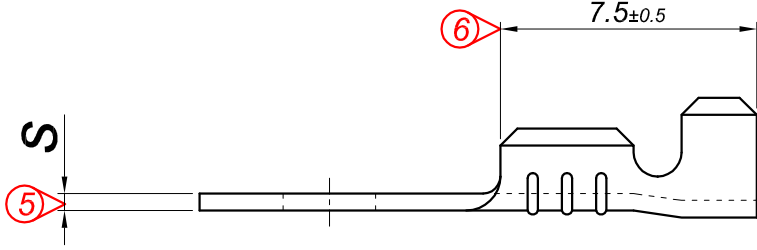
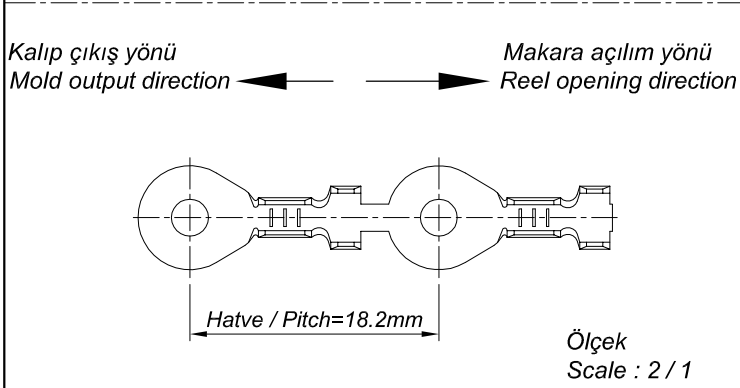

Kablo Kesiti

Wire Section : 0.25 - 0.50 mm²

Resim üzerinden ölçü almayınız
do not measure on drawing

Tarih / Date	07.12.2014	İmza /Signature	Ölçek /Scale		
Çizen / Desing	M.Yağcı		5 / 1		
Onay / Approval	S.Gölcük		No	Değişiklik / Revision	Tarih/Date



Parça Adı:
Part Name

1 NO 2.TERMİNAL
KÜÇÜK AYAK Ø2.7

Parça Kodu:
Part Code

TŞ 2466